

What Is a Structural Measurement Process?*

Lev Goldfarb and Oleg Golubitsky

November 30, 2001

Abstract

Numbers have emerged historically as by far the most popular form of representation. All our basic scientific paradigms are built on the foundation of these, numeric, or quantitative, concepts. Measurement, as conventionally understood, is the corresponding process for (numeric) representation of objects or events, i.e., it is a procedure or device that realizes the mapping from the set of objects to the set of numbers. Any (including a future) measurement device is constructed based on the underlying mathematical structure that is thought appropriate for the purpose. It has gradually become clear to us that the classical numeric mathematical structures, and hence the corresponding (including all present) measurement devices, impose on “real” events/objects a very rigid form of representation, which cannot be modified dynamically in order to capture their combinative, or compositional, structure. To remove this fundamental limitation, a new mathematical structure—*evolving transformation system (ETS)*—was proposed earlier. This mathematical structure specifies a radically new form of object representation that, in particular, allows one to capture (inductively) the compositional, or combinative, structure of objects or events. Thus, since the new structure also captures the concept of number, it offers one the possibility of capturing simultaneously both the qualitative (compositional) and the quantitative structure of events. In a broader scientific context, we briefly discuss the concept of a fundamentally new, biologically inspired, “measurement process”, the *inductive measurement process*, based on the ETS model. In simple terms, all existing measurement processes “produce” numbers as their outputs, while we are proposing a measurement process whose outputs capture the representation of the corresponding class of objects, which includes the class projector (a non-numeric entity) plus the class transformation system (the structural class operations). Such processes capture the structure of events/objects in an inductive manner, through a direct interaction with the environment.

*This paper is a substantially expanded version of the conference paper [1].

Our instruments of detection and measurement, which we have been trained to regard as refined extensions of our senses, are they not like loaded dice, charged as they are with preconceived notions concerning the very things which we are seeking to determine? Is not our scientific knowledge a colossal, even though unconscious, attempt to counterfeit by number the ... world disclosed to our senses?

Tobias Dantzig, *Number: The Language of Science* (1954)

1 Introduction

In this paper we introduce the concept of inductive, or structural, measurement device, which represents a radical departure from the concept of classical measurement device. The adjective “radical” is quite justifiable, since it has become clear to us that the nature of departure is such that, once the proposal is fully adopted, mathematics and especially all basic natural sciences, including physics and chemistry, will seethe to exist in their present form. What are the reasons that could justify such a sweeping claim?

A short answer to the question is this. Mathematics, but particularly basic natural sciences, have very gradually evolved *together with* well elaborated techniques of measurement and various measurement devices. It is also well known that, ultimately, all such techniques are inextricably linked to the structure of the set \mathbb{N} of natural numbers, whose emergence predates considerably all of the former. At the same time, both the historical evidence [2] (see also Section 3) and the Peano axiomatic description of \mathbb{N} (i.e., “1” plus the successor operation, see [3]) strongly suggest the inductive nature and inductive structure of the set \mathbb{N} . Thus, with the emergence of a fundamentally new mathematical structure — *evolving transformation system (ETS)* [4, 5, 6, 7, 8] — that captures the process of inductive construction in a more general (than that corresponding to Peano construction), “structural”, or compositional, form, a number of important formal and informal reasons came to the fore that justify the above claim. Again, to intuit these reasons from a drastically simplified example (clarified throughout the paper), it might be enough to imagine the development of an empirical investigation based on the substitution of the set \mathbb{N} of natural numbers, the starting point of most scientific developments, by an inductively constructed set of symbolic entities (*structs*) with the interrelations defined by means of symbolic transformations directly related to their inductive construction (see Section 2 and [9]). Since from formal point of view the constructed set of structs bares hardly any resemblance to the set \mathbb{N} , *the measurement device (used in the investigation) that outputs the corresponding structs instead of numbers* cannot fail to produce the view of “reality” quite different from the classical one (see Fig. 3). In what follows, however, we also demand from the measurement device the capability to discover during the measurement process — which is, in essence, an inductive learning process — the transformations needed to accomplish the inductive construction of the class to which the measuring object belongs. Thus, the generalized measurement process reduces mainly to the corresponding inductive learning process, which is able to capture the object’s representation in an evolving manner (dependent on the context). It is also important to keep in mind that the term “inductive learning” is used here in a (new) sense specified by Definition 1 in the next section.

2 The inductive learning process and the evolving transformation system model

We begin with the following model-independent definition of the inductive learning process, the process which in our accepted understanding of “intelligence” occupies an absolutely central role.

Definition 1. Given a small finite set R of objects that are randomly generated elements of a (possibly infinite) class \mathbf{K} — class to be learned — the inductive learning process has to construct an **inductive class representation** of \mathbf{K} . ►

In [9], we presented a formal model of structural (including class) representation that formalizes the above intuitive definition. In this paper, we illustrate the concepts of this model on a simple example. The environment in the example is a set of closed rectilinear planar shapes. Accordingly, in the following subsections, we introduce the *shape inductive structure* and the *class of shapes*. We describe the *generating process* for this class and compute the *typicality measure* induced on the set of shapes by this process. Then, we discuss how a particular *subclass* (of the cross shapes) can be *learned* from a small finite set of training examples (according to the learning criterion presented in [9]).

2.1 The inductive structure for the “shape” example

Let us denote the set of prims [9, Def. 1] for the **shape inductive structure** as Π_{Sh} (Fig. 1). Moreover, the set of semantic identities [9, Def. 6] is defined as the union of the set of commutativity identities $\text{Comm}(\Pi_{Sh})$ [9, Def. 13] and the set of identities shown in Fig. 2.

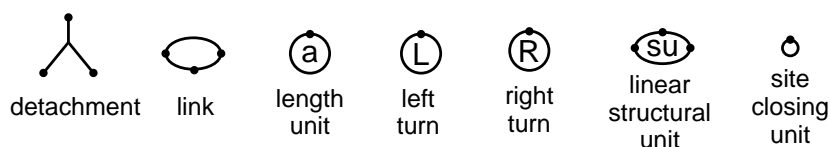

Figure 1: Primitive types of the shape inductive structure.

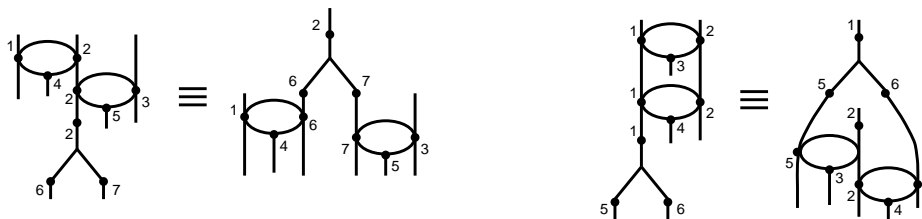

Figure 2: Semantic identities of the shape inductive structure.

An example of a shape and the corresponding struct [9, Defs. 9,21] from the shape inductive structure is shown in Fig. 3.

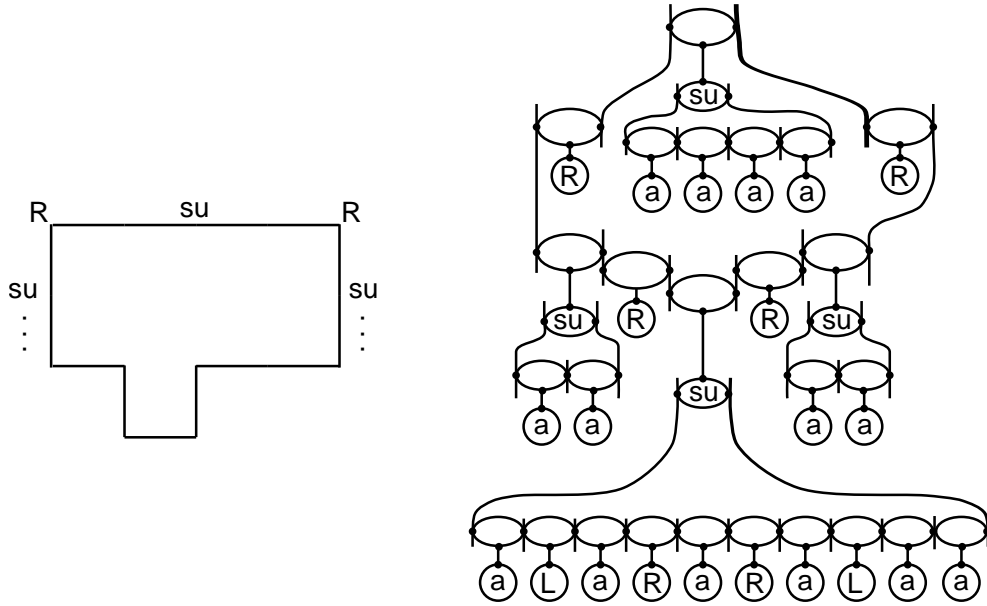

Figure 3: A rectilinear shape (left) and the corresponding struct (right).

2.2 The class of shapes in the shape inductive structure

Next, we define the class [9, Def. 34] \mathbf{C} of shapes. In the ETS model, a class is specified by a transformation system [9, Def. 21] consisting of a progenitor, which is, in our case, the smallest square shape, and a set of weighted transformations [9, Defs. 14–16,21], which specify the stochastic generating process [9, Def. 33]. The latter, starting from the square-progenitor, generates all other class shapes by applying transformations.

To intuit these transformations, it is sufficient to view the shapes as consisting of “linear structural units”; the linear structural units of the shape in Fig. 3 are shown in Fig. 4. By relying on the concept of a linear structural unit and the corresponding primitive (su) in the shape inductive structure (Fig. 1), we can construct transformations applicable to entire structural units, no matter how complex they may become (see the *shift* transformations $\bar{\tau}_{shl}, \bar{\tau}_{shr}$ in Fig. 5).

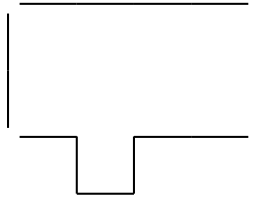

Figure 4: The linear structural units of a shape.

The transformation system for our class \mathbf{C} (Fig. 5) consists of the progenitor $\bar{\kappa}$ and the following transformations: side extension ($\bar{\tau}_a$ for an empty side and $\bar{\tau}_{ia}$ for a non-empty side), creation of a linear structural unit ($\bar{\tau}_{su}$), left and right shifts of a structural unit ($\bar{\tau}_{shl}, \bar{\tau}_{shr}$), left and right protrusions ($\bar{\tau}_{pl}, \bar{\tau}_{pr}$). We also introduce a “death” transformation $\bar{\tau}_x$ which, if applied to a struct, prevents the application of any other transformation, and thus terminates the generating process.

The formal definition of the death transformation is completely analogous to that for the class of strings [9, Section 3.7].

In what follows, it will be convenient to denote by u_i the *inverse* weight of the transformation $\bar{\tau}_i$, $i \in \{a, ia, su, shl, shr, pl, pr, x\}$.

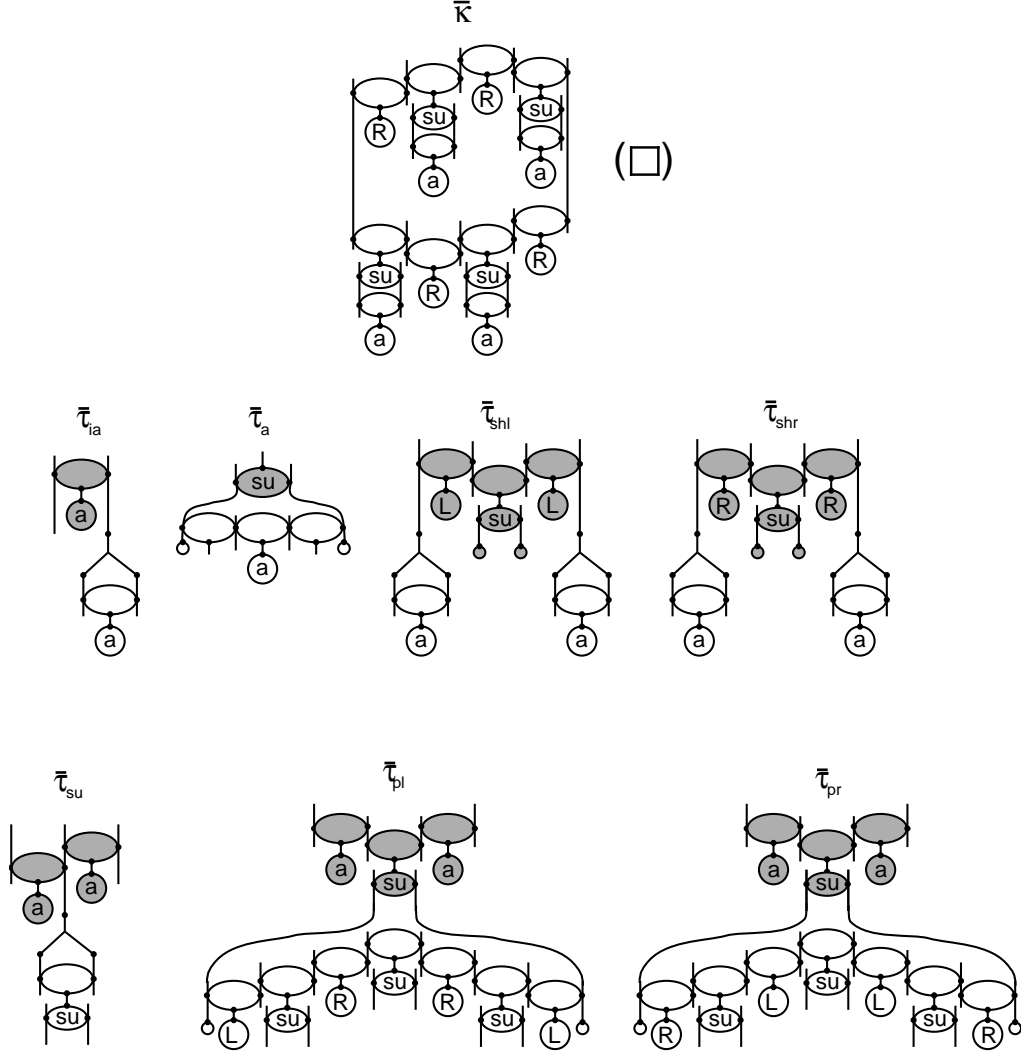

Figure 5: The progenitor (top row) and transformations of the class **C** (the shaded parts correspond to the contexts).

Important remark. We would like to note that our design of inductive structure Π_{Sh} , i.e. the choice of primitives and identities, was guided by a particularly chosen intuitive understanding of the nature of transformations involved in the definition of class **C** (this class serves the role of the superclass [9, Section 4]).

2.3 Generating process and the typicality measure for the class of shapes

The generating process for the class **C** can be thought of as a combination of four parallel generating processes, each starting its action on one of the four sides of the progenitor square for class **C**. For

example, consider the cross shape depicted in Fig. 6. The part of the process, that corresponds to the generation of one leaf of the cross shape, is shown in Fig. 7.

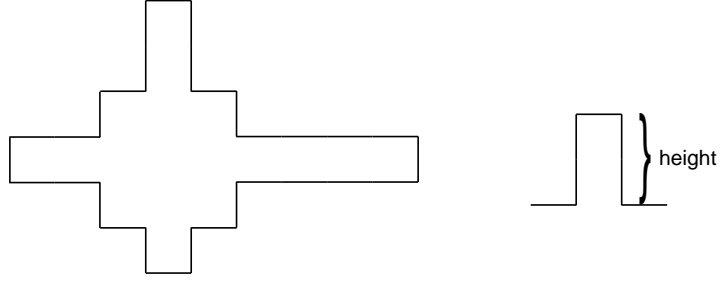

Figure 6: A cross shape and one of its leaves.

Let $\bar{\gamma}_m$ be the struct corresponding to the cross shape with four leaves each of height m . Denote by $f_m(t)$ the probability that at time t the process that generates a leaf of the cross shape is in the state $\bar{\delta}_m$ corresponding to the leaf of height m (e.g., the last three shown states in Fig. 7 correspond to leaves of height 0, 1, and 2). Let $\bar{\delta}_{\bar{\kappa}}$ denote the initial state, i.e., the state corresponding to any one of the sides of the progenitor square. Since the probability that the generating process for our class of shapes will be in state $\bar{\gamma}_m$ at time t is

$$f_m(t)^4 e^{-u_x t},$$

the expected time the process will spend in $\bar{\gamma}_m$ is

$$E_{\mathbf{C}}(\bar{\gamma}_m) = \int_0^{\infty} f_m(t)^4 e^{-u_x t} dt. \quad (1)$$

Next, by definition, the expected running time of the process is

$$E_{\mathbf{C}} = \sum_{\bar{\gamma} \in \mathbf{C}} E_{\mathbf{C}}(\bar{\gamma}).$$

Note that the process is running until $\bar{\tau}_x$ is applied. Since $\bar{\tau}_x$ is acting independently of all the other transformations, $E_{\mathbf{C}} = 1/u_x$.

According to [9, Def. 35], the typicality of $\bar{\gamma}_m$ is

$$\mathbf{g}_{\mathbf{C}}(\bar{\gamma}_m) = \frac{E_{\mathbf{C}}(\bar{\gamma}_m)}{E_{\mathbf{C}}} = u_x \int_0^{\infty} f_m(t)^4 e^{-u_x t} dt. \quad (2)$$

In what follows, we will need an upper bound for $\mathbf{g}_{\mathbf{C}}(\bar{\gamma}_m)$, so, next, we estimate $f_m(t)$ from above.

It follows from [10, Lemma 2] that for the leaf of height m (see the corresponding generating process in Fig. 7), the probability that the process will be in state $\bar{\delta}_m$ at time t , starting from $\bar{\delta}_0$, is

$$f_0^m(t) = u_{shr}^m e^{-vt} \sum_{k=0}^m \frac{e^{-2ku_{ia}t} (2u_{ia})^{-m}}{k!(m-k)!} = \left(\frac{u_{shr}}{2u_{ia}} \right)^m e^{-vt} \frac{1}{m!} (e^{-2u_{ia}t} + 1)^m \leq \frac{1}{m!} \left(\frac{u_{shr}}{u_{ia}} \right)^m e^{-vt},$$

where $v = 2u_{shr} + 3u_{ia} + 2u_a$.

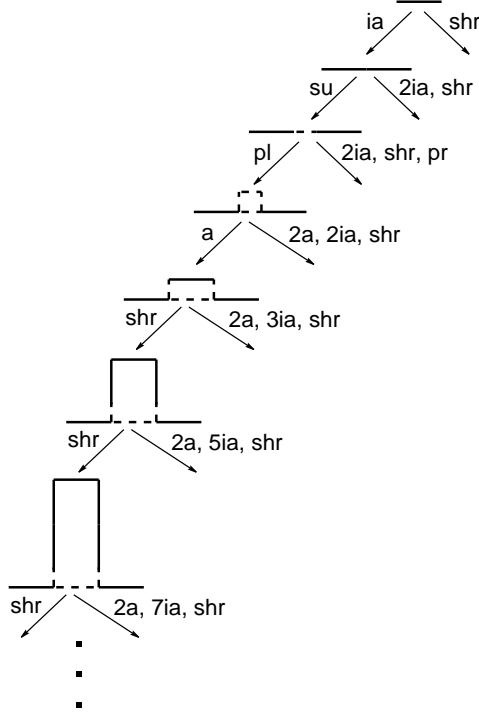

Figure 7: Generating process for one of the cross leaves. The notation $(2ia, shr, pr)$ signifies the set of four elementary paths [9, Def. 28] with the indicated transformations each ending at some (not shown) struct.

From [10, Lemma 3], we have that the probability that the generating process will be in state $\bar{\delta}_m$ at time t (starting from $\bar{\delta}_{\bar{K}}$) is

$$f_m(t) = \int_0^t g_0(\xi) f_0^m(t - \xi) d\xi \leq \frac{1}{m!} \left(\frac{u_{shr}}{u_{ia}} \right)^m \int_0^t g_0(\xi) e^{-v(t-\xi)} d\xi = \frac{1}{m!} \left(\frac{u_{shr}}{u_{ia}} \right)^m f_0(t),$$

where $g_0(\xi)$ denotes the probability density that the process will reach state $\bar{\delta}_0$ at time ξ , starting from $\bar{\delta}_{\bar{K}}$.

Hence, from (2), we obtain

$$\mathbf{g}_{\mathbf{C}}(\bar{\gamma}_m) \leq u_x \frac{1}{(m!)^4} \left(\frac{u_{shr}}{u_{ia}} \right)^{4m} \int_0^\infty f_0(t)^4 e^{-u_x t} dt \quad (3)$$

and

$$\mathbf{g}_{\mathbf{C}}(\bar{\gamma}_0) = u_x \int_0^\infty f_0(t)^4 e^{-u_x t} dt. \quad (4)$$

2.4 A subclass of the class of shapes

Consider the subclass [9, Def. 40] of cross shapes $(id_{\mathbf{K}}, \mathbf{K})$ of \mathbf{C} . The transformation system for \mathbf{K} consists of the progenitor $\bar{\gamma}_0$ (cross shape with all leaves of height 0) and two transformations, $\bar{\tau}_{shr}$ and $\bar{\tau}_x$, from the transformation system for \mathbf{C} . Morphism $id_{\mathbf{K}}$ is the identity morphism on \mathbf{K} whose mapping is the identity embedding $id_{\mathbf{K}} : K \rightarrow C$.

In Fig. 8, a “part” of the generating process for class \mathbf{K} corresponding to one leaf of the cross shape is shown.

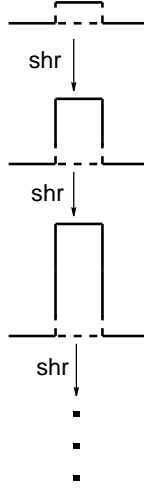

Figure 8: Generation of a leaf of a cross shape in class \mathbf{K} .

From [10, Lemma 5], it follows that the probability that the part of the generating process shown in Fig. 8 is in the state corresponding to a cross leaf of height m at time t is

$$h_m(t) = u_{shr}^m \frac{t^m}{m!} e^{-u_{shr}t}.$$

Hence,

$$\begin{aligned} \mathbf{g}_{\mathbf{K}}(\bar{\gamma}_m) &= u_x \int_0^\infty h_m(t)^4 e^{-u_x t} dt = u_x \int_0^\infty \left(u_{shr}^m \frac{t^m}{m!} e^{-u_{shr}t} \right)^4 e^{-u_x t} dt = \\ &= u_x \left(\frac{u_{shr}}{4u_{shr} + u_x} \right)^{4m} (4u_{shr} + u_x)^{-1} \frac{(4m)!}{(m!)^4}. \end{aligned} \quad (5)$$

2.5 Learning the subclass of cross shapes in the class of shapes

In our inductive learning environment, let the superclass [9, Section 4] be the class \mathbf{C} of shapes. Moreover, let $R = \{\bar{\gamma}_m\}$ be a training set [9, Section 4] consisting of a single element — the cross shape with all leaves of height m . Consider the following three subclasses [9, Def. 40] of the superclass \mathbf{C} : \mathbf{C} itself, $(\text{id}_{\mathbf{C}}, \mathbf{C})$, the subclass of cross shapes defined above, $(\text{id}_{\mathbf{K}}, \mathbf{K})$, and the class with a single element $\bar{\gamma}_m$, $(\text{id}_{\{\bar{\gamma}_m\}}, \{\bar{\gamma}_m\})$. We will show that the solution to the learning problem for the above training set R in \mathbf{C} [9, Section 4] is a non-trivial class, by proving that for all except several small values of m , the learning optimization criterion given in [9, Section 4] will choose subclass $(\text{id}_{\mathbf{K}}, \mathbf{K})$ over $(\text{id}_{\mathbf{C}}, \mathbf{C})$ or $(\text{id}_{\{\bar{\gamma}_m\}}, \{\bar{\gamma}_m\})$.

In fact, the above learning problem was formulated as follows: given R , find subclass $(\mathbf{f}^0, \mathbf{K}^0)$ which maximizes

$$\mathbf{g}_{(\mathbf{f}^0, \mathbf{K}^0)}(R^0) \cdot \mathbf{g}_{\mathcal{P}(\mathbf{C})}(\bar{\xi}_{(\mathbf{f}^0, \mathbf{K}^0)}).$$

Consider the resulting expressions (to be optimized) for each of the three subclasses:

$$\begin{aligned} A_{\mathbf{C}} &= \mathbf{g}_{\mathbf{C}}(\bar{\kappa}_{\mathbf{C}}) \cdot M_{\mathbf{C}} \cdot \mathbf{g}_{\mathbf{C}}(\bar{\gamma}_m) \leq \mathbf{g}_{\mathbf{C}}(\bar{\gamma}_m) \\ A_{\bar{\gamma}_m} &= \mathbf{g}_{\mathbf{C}}(\bar{\gamma}_m) \cdot M_{\bar{\gamma}_m} \cdot 1 \leq \mathbf{g}_{\mathbf{C}}(\bar{\gamma}_m) \\ A_{\mathbf{K}} &= \mathbf{g}_{\mathbf{C}}(\bar{\gamma}_0) \cdot M_{\mathbf{K}} \cdot \mathbf{g}_{\mathbf{K}}(\bar{\gamma}_m) \end{aligned}$$

Here $M_{\mathbf{C}}$, $M_{\bar{\gamma}_m}$, and $M_{\mathbf{K}}$ each stand for the typicalities of the corresponding class transformation sets. Note that $M_{\mathbf{K}}$ is a positive constant (independent of $\bar{\gamma}_m$). Next, for the inequalities $A_{\mathbf{C}} < A_{\mathbf{K}}$ and $A_{\bar{\gamma}_m} < A_{\mathbf{K}}$ to be satisfied, it is sufficient to satisfy the inequality $\mathbf{g}_{\mathbf{C}}(\bar{\gamma}_m) < A_{\mathbf{K}}$. Expanding the latter inequality, using (3,4,5), yields

$$u_x \left(\frac{u_{shr}}{u_{ia}} \right)^{4m} \frac{1}{(m!)^4} < u_x \cdot M_{\mathbf{K}} \cdot u_x \left(\frac{u_{shr}}{4u_{shr} + u_x} \right)^{4m} (4u_{shr} + u_x)^{-1} \frac{(4m)!}{(m!)^4},$$

or

$$(4m)! \left(\frac{u_{ia}}{4u_{shr} + u_x} \right)^{4m} > \left(1 + \frac{4u_{shr}}{u_x} \right) \frac{1}{M_{\mathbf{K}}}.$$

The latter inequality holds if

$$m > \max \left(\frac{e^2}{4} \cdot \frac{(4u_{shr} + u_x)^2}{u_{ia}u_x}, \frac{1}{4M_{\mathbf{K}}} \right). \quad (6)$$

The first argument of the maximum is more important than the second; it shows that the smaller u_{ia} and the larger u_{shr} and u_x are, the less likely (\mathbf{f}, \mathbf{K}) is to be learned. This is understandable, since the growth of u_{shr} relative to u_{ia} makes the generating process for \mathbf{K} closer to that for \mathbf{C} , and thus the typicality of $\bar{\gamma}_m$ in \mathbf{K} approaches its typicality in \mathbf{C} , so that there is less advantage in choosing \mathbf{K} instead of \mathbf{C} or $\{\bar{\gamma}_m\}$. If u_x tends to infinity, any training set becomes very non-typical, thus the non-trivial subclass will not be learned. More accurately, the typicality of $\bar{\gamma}_0$ in \mathbf{C} will tend to zero much faster than that of $\bar{\kappa}_{\mathbf{C}}$, while the typicalities of $\bar{\gamma}_m$ in \mathbf{C} and in \mathbf{K} will be infinitely small values of the same order, which will make \mathbf{C} and $\{\bar{\gamma}_m\}$ better choices than \mathbf{K} .

The important conclusion is that for any values of the transformation weights for superclass \mathbf{C} , the training set consisting of a single (moderately large) positive example is enough to learn at least a non-trivial subclass, which is very likely to be the class of cross shapes \mathbf{K} . It is not difficult to see that with two training examples, we will need a much weaker restriction on their sizes to avoid the non-trivial subclasses. Although the presented example is very simple, it suggests at least one of the reasons why the proposed learning criterion might “work” (even for a small training set).

2.6 On the nature of the ETS inductive class representation and the central role of learning processes

Note both the generative (and, therefore, mainly discrete) nature of the inductive class representation, as well as the tight coupling between the training set of objects R and the constructed inductive class representation \mathbf{K} . Since the latter coupling is not possible in any classical discrete model (e.g. Chomsky’s formal grammar), the presence of a “continuous element” in the model becomes necessary, which is not obvious from the original Definition 1. These two conventionally incompatible features of the model, *combined in a new and natural way*, make the ETS model unique among all other models of inductive learning. The uniqueness of the ETS model was also brought out by our recent discussion [11] which indicates why *the well known “inductive learning” models, particularly neural net models, are not inductive learning models at all.*

Without going into a more complete justification of why the inductive learning process can be considered as the prime candidate for the central intelligent process, we simply point to the ubiquitous fact that, in all biological species, an object/event representation is always based on the finite number of the agent's encounters, direct and indirect, with that object/event. No doubt, this is the reason why induction has occupied a prominent role in the history of philosophy in general, and philosophy of science in particular.

3 Numbers, variables, and measurements

As was outlined in [2, Section 3], the process of emergence of the concept of number can be divided into 4 stages: the ability to compare reasonably accurately the sizes of *some* sets of objects; selection of a few reference, or standard, sets of objects for the purpose of explicit storage of the corresponding set sizes; selection of a single standard set of objects for the same purpose; emergence of the abstract concept of number independent of the reference set.

Remarkably, it appears that the well known in mathematics Peano axiomatic description of natural numbers (see, for example [3]) through the axiom of induction captures the critical role of inductive *cognitive* processes in the creation of numbers. In other words, the hypothesis [2] is that the decisive and irreplaceable role of the axiom of induction is not an accident but a true reflection of the inductive origin of numbers, where the number is a representation of a finite set size. It is important to emphasize this point again: *numbers have emerged inductively to represent sizes of various sets of objects, or events.*

The relatively recent processes of introduction of rational and real numbers are understood much better and are, of course, built on the foundation of natural numbers, the fact that is succinctly captured in the well known in mathematics statement by L. Kronecker: "God made the natural numbers, all the rest is the work of man".

"Entire centuries [in fact, several millenniums] had to pass before well-elaborated and differentiated methods and techniques of measurement had been successively established in various scientific disciplines. This process was connected with the development of mathematics and other sciences and with the advancement of the technology of measurement which was enforced by the demands of production, trade, communication, and the like.

Ordinarily, when we use measurement procedures, we are not at all aware of this complex historical development. Weighing trade articles on various kinds of balances, measuring time by using clocks, measuring the speed of a car with the help of an odometer — these are operations which are performed by contemporary man in a mechanical manner. These operations appear very easy and obvious. In order to find out the time, weight or speed of something, to be able to say how heavy it is, what time it is, or how quickly we drive, is it not sufficient only to watch the pointer on the scale of the respective measurement device? This way of measurement by *reading* the data off the scales of measurement tools or instruments seems so easy only because we do not consider all the necessary empirical and theoretical presuppositions which facilitated the construction and employment of these measurement devices" [12, pp. 1–2].

Given a fixed "property", a prototypical classical measurement process might be thought of as a process of "systematic" (i.e. by prescription) assignment of numbers to objects that reflects the "amount" of this fixed property as possessed by the object. To "legalize" a property the corresponding variable is introduced, and thus properties acquire official names. But what is a "property"? Does it exist independent of the corresponding process of measurement? In particular: "Is length anything more than what we measure when we make a length measurement according to prescription?" [13, p. 137] The answer that an outstanding physicist P. W. Bridgman gave is that

the “properties” do not really exist outside the measuring process: “It . . . is [more appropriate] not to talk about measuring a ‘length’, but instead to talk about making a ‘length-measurement’. Or better still, talk about ‘length-measuring’, the length being an adverb” [13, p. 137]. In other words, the “property”, or concept, of length can only be introduced via the corresponding measurement process. What is this measurement process (in the case of length)? It is not difficult to see that the ETS inductive class representation of the set \mathbb{N} of natural numbers [9, Section 3.8] holds the key to the answer: to measure length (in integer units) *means* to choose a linear unit of measurement, \mathbf{a} , and to apply it successively, so that the result of the measurement process is the *representation of the length* as $\mathbf{aaa} \dots \mathbf{a}$. The extension of this process to non-integer units of measurement should now be clear enough.

Thus, in essence, *the classical measurement process can (and properly should) be viewed as a systematic environment-dependent procedure for constructing for a given object the corresponding element of \mathbb{N} , where \mathbb{N} is the class isomorphic to the class of strings [9, Section 3.7] over a single-letter alphabet $A = \{\mathbf{a}\}$ and \mathbf{a} corresponds to the chosen unit of measurement.*

4 The structural (inductive) measurement process

In order to generalize the classical measurement procedure, it remains for us to finally view the classical procedure as the construction of the object representation where the representation set, \mathbb{N} , itself was *inductively constructed once and for all* long time ago. The choice of the classical (numeric) representation set may explain why the conventional measurement process, and therefore all classical physical models, are reversible.¹

In contrast, the inductive measurement process is performed by an agent that has knowledge of several classes, some of which are related to each other via monomorphisms [9, Def. 40]; the structure of these classes does not have to be as simple as that of \mathbb{N} . Moreover, the agent’s knowledge is dynamically modified by adding the learned subclasses.

Definition 2. By a **structural, or inductive, measurement process** we mean a systematic environment-guided procedure that constructs for a given object, during the inductive learning process, the corresponding inductive (structural) representation. ►

In our current formalism, we propose to split the inductive measurement process into two phases:

1. The *measurement phase*, i.e., the environment-guided construction of the set R of representations for the objects in the training set with respect to the fixed superclass \mathbf{C} .
2. The *learning phase*, i.e., the agent’s (internal) construction, based on the training set R , of the transformation system for the corresponding subclass (\mathbf{f}, \mathbf{K}) from the training set R and the representation of the training set with respect to class \mathbf{K} .

4.1 The measurement phase

Consider the agent that has knowledge of several classes, some of which are related to each other via monomorphisms [9, Def. 40]. For example, the agent’s knowledge may consist of a single class of shapes, or of two classes, the class of shapes and the subclass of cross shapes. When the agent encounters a “physical” object, he attempts to construct a “representation” of the object by

¹For a discussion of the relevant issues see, for example, [14, 15].

discovering its formative history *based* on the agent’s knowledge of some classes, i.e., the classes activated by the object. Thus, for example, if the above agent encounters a cross shape, both classes, of shapes and of cross shapes, are activated; if the agent encounters a shape of a different kind, only the class of shapes is activated. The agent accomplishes the construction of object’s representation by initiating the generating process for each of the active classes. Each such process is conditioned by the above relationship (via monomorphisms) between the classes and is simultaneously “guided” by the agent’s structural measurement devices. The function of the *structural measurement device* is to match the structs from some of the active classes against the original “physical” object. In case of the class of shapes, the matching is between the current state of the process and a part of the presented external shape. For each of the active classes, the current state, or struct, of the corresponding generating process can be called the current representation of the “physical” object with respect to that active class.

4.2 The learning phase

Again, suppose the agent knows only the class of shapes \mathbf{C} and encounters several cross shapes. Then, during the measurement phase, it would construct for each cross shape its representation with respect to \mathbf{C} , which has the form $(\bar{\gamma}, \mathbf{C})$.

During the learning phase, in this case, the transformation system for subclass (\mathbf{f}, \mathbf{K}) is constructed as described in Section 2.5. Construction of the subclass (\mathbf{f}, \mathbf{K}) would yield some representation of the form $(\bar{\alpha}, \mathbf{K})$, when the agent again encounters a cross shape.

It is important to note that since a subclass has fewer paths from its progenitor to a struct (than its superclass), the search for, or construction of, an object’s representation in the subclass, which is performed during the measurement phase, is simpler than that in the superclass. Thus, the representation of the more complex objects during the next round of the measurement process becomes possible. For example, the “new” agent is able to represent more complex cross shapes than the “old” agent. Moreover, the subclass \mathbf{K} does not require such a complex inductive structure as the shape inductive structure; in fact, \mathbf{K} is isomorphic to the class $\mathbf{C}_{\mathbb{N}^4}$ of four-tuples of natural numbers, which can be defined similarly to the class of natural numbers [9, Section 3.8]. Hence, the first component of the representation, struct $\bar{\gamma}$, can also be “simplified” after learning, yielding a new representation of the form $(\bar{\gamma}', \mathbf{C}_{\mathbb{N}^4})$.

The class of cross shapes is too simple to consider the process of learning of its subclasses, but, in general, more complex objects become representable in the subclass and they, in turn, may initiate the new learning phase. This appears to be the general scheme of the development of the agent’s knowledge.

5 Conclusion

We introduced the concept of a structural, or inductive, measurement process which is a far-reaching generalization of the classical, numeric, measurement process. The main steps are, first, to replace the numeric representation space by the recently introduced [9] structural representation space, and, second, to add the dynamic component into the measurement process by identifying that process with the inductive learning process. The second feature endows the process with the capability to record much more accurately the interaction of the agents with the environment. Such interactions can be recorded, as all inductive processes suggest, only on the basis of the agent’s past history and the present context. It is interesting to note that the necessity of this second, interactive, feature of the measurement process can be explained by the simple fact that the variety

of inductive learning constructions, and therefore of the object/class structural representation is incomparably richer than that under the numeric representation.

It might also be useful to mention that ETS model should be consistent with the following physical picture (originating from the Epicurian school [16, p. 26] and advanced in the middle of this century by the outstanding Soviet physicist A.Ya. Frenkel): the motion of an elementary particle can be considered as the discrete-time process of *regeneration* of that particle in various discrete space cells along its “trajectory”, i.e. the space-time consists of interacting quantum, or discrete, cells, through which the “motion” is perceived and within which no classical “motion” occurs [16, pp. 148–152].

What are the implications to the basic natural sciences? Several points could be mentioned here. It appears that the switch to structural representations may remove many of the present basic difficulties, including the inconsistencies between the macro- and micro-pictures of reality.² What are the reasons that justify this hope?

All present and future measurement devices, around which the *natural* sciences have evolved and probably will continue to evolve, are based on some mathematical models. Up to the present, the set of natural numbers has embodied the mother-model, i.e. Peano model, of all applied mathematical models and therefore implicitly served as the starting point of all scientific investigations. The substitution of \mathbb{N} by more general, structural, inductive models allows one to record *dynamically* the interaction of the inductive, or structural, measurement process with the environment, as was explained above. Such new measurement processes will resemble biological “measurement processes”, and, indeed, the former are inspired by the latter and hence can be considered as more “real” than our present measurement processes. Moreover, it is quite possible that with the corresponding developments mathematics itself will be reshaped in a more streamlined manner, in which the structural operations and their weights will play the unifying role.

References

- [1] L. Goldfarb, S. Deshpande, What is a symbolic measurement process?, *Proc. IEEE Conf. Systems, Man, and Cybernetics, Vol. 5*, Orlando, Florida, USA, pp. 4139–4145, 1997.
- [2] L. Goldfarb, Inductive theory of semiotic systems, *Proc. Intelligent Systems and Semiotics: A Learning Perspective*, 22–25 Sept. 1997, Gaithersberg, Maryland, U.S.A. (in press).
- [3] E.G.H. Landau, *Foundations of Analysis*, Chelsea, New York, 1951.
- [4] L. Goldfarb, On the foundations of intelligent processes I: An evolving model for pattern learning, *Pattern Recognition 23*, 595–616, 1990.
- [5] L. Goldfarb, What is distance and why do we need the metric model for pattern learning, *Pattern Recognition 25*, 431–438, 1992.
- [6] L. Goldfarb and S. Nigam, The unified learning paradigm: A foundation for AI, in *Artificial Intelligence and Neural Networks: Steps toward Principled Integration*, eds. V. Honavar and L.Uhr, Academic Press, Boston, 1994.

²As is well known, such inconsistencies came to the fore with the development of quantum physics during the first half of this century.

- [7] L. Goldfarb, What is inductive learning? Construction of inductive class representation, *Proc. Workshop What Is Inductive Learning*, ed. L. Goldfarb, 9–21, Faculty of Computer Science, U.N.B., Fredericton, New Brunswick, 1996.
- [8] L. Goldfarb, Inductive class representation and its central role in pattern recognition, *Proc. 1996 Conf. on Intelligent Systems: A Semiotic Perspective*, eds. J. Albus, A. Meystel, R. Quintero, Vol. I, 53–58, NIST, Gaithersberg, Maryland, 1996.
- [9] L. Goldfarb, O. Golubitsky, D. Korkin, What is a structural representation? *Technical Report TR00-137*, Faculty of Computer Science, U.N.B., October 2001.
- [10] O. Golubitsky, On the generating process and the class typicality measure. *Technical Report*, Faculty of Computer Science, U.N.B., November 2001.
- [11] L. Goldfarb, J. Hook, Why classical models for pattern recognition are not pattern recognition models, *Proc. Intern. Conf. On Advances in Pattern Recognition*, Plymouth, UK, pp. 405–414, 1998.
- [12] K. Berka, *Measurement: Its Concepts, Theories and Problems*, D. Reidel Publ., Dordrecht, Holland, 1983.
- [13] P.W. Bridgman, *The Way Things Are*, Harvard University Press, Cambridge, Massachusetts, 1966.
- [14] I. Prigogine, *Order out of Chaos*, Bantam Books, Toronto, 1984.
- [15] I. Prigogine, *The End of Certainty: Time, Chaos, and the New Laws of Nature*, The Free Press, New York, 1997.
- [16] B.G. Kuznetsov, *Relativity: Evolution of the Relativity Principle from Antiquity to the Present Day*, Znaniye Publ., Moscow, 1969 (in Russian).